

P 057

Lievensteg 6

41352 Korschenbroich

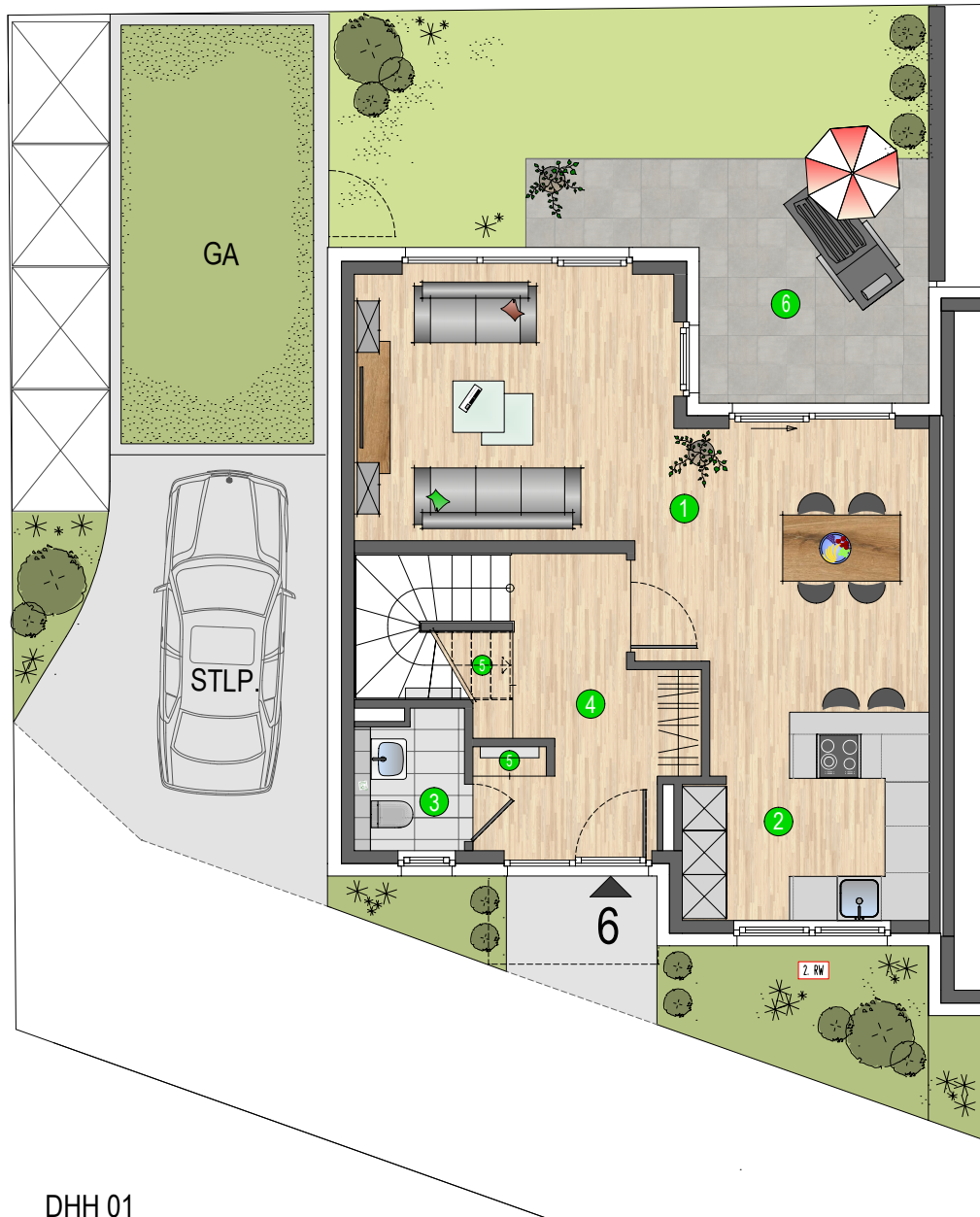

DHH 01

Erdgeschoss

①	Wohnen/Essen	30,68 m ²
②	Küche	8,19 m ²
③	WC	2,72 m ²
④	Eingang/Diele	8,46 m ²
⑤	Abstellen/HA	2,76 m ²
⑥	Terrasse 13,26 m ² (50%)	6,63 m ²

Wohnfläche EG 59,44 m²

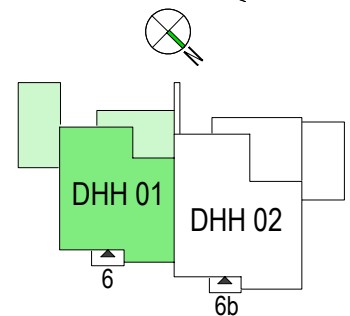

P 057

Lievensteg 6

41352 Korschbroich

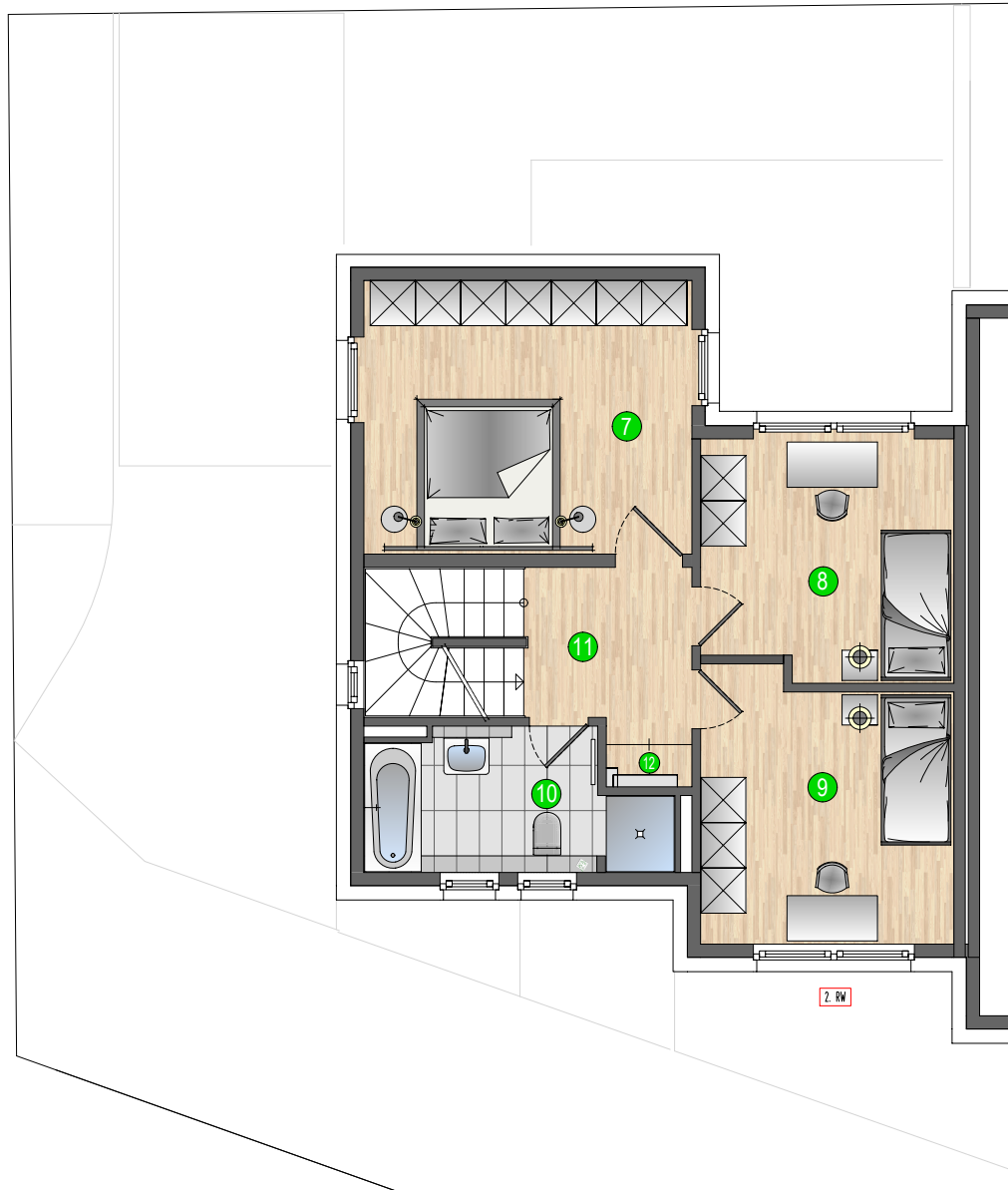

DHH 01

Obergeschoss

7	Schlafen	15,78 m ²
8	Kind / Arbeiten 1	10,43 m ²
9	Kind / Arbeiten 2	11,64 m ²
10	Bad	6,83 m ²
11	Flur	4,84 m ²
12	Abstellen	0,64 m ²

Wohnfläche OG 50,16 m²

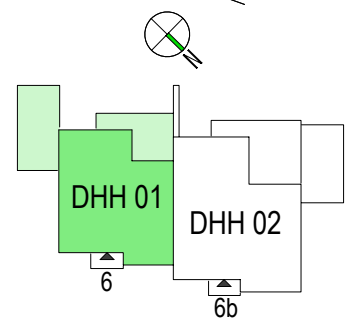

1.00

P 057

Lievensteg 6

41352 Korschenbroich

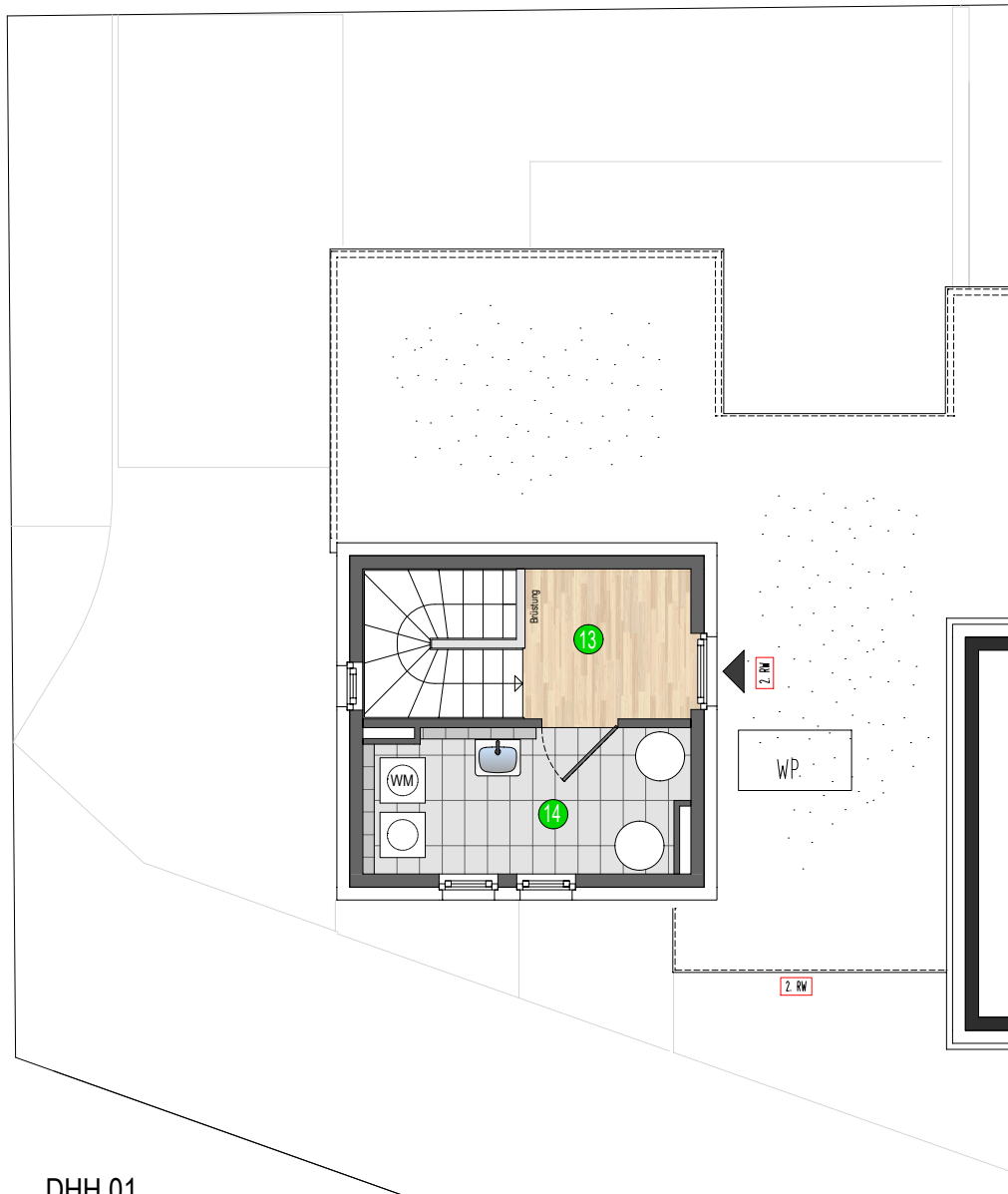

DHH 01

Staffelgeschoss

13	Flur	4,41 m ²
14	Abstellen; HWR; HAR	8,05 m ²

Wohn-/Nutzfläche STG 12,46 m²

Wohn-/Nutzfläche Gesamt= 122,06 m²

Grundstücksanteil 152,72 m²
(Gebäudegrundfläche + SNR)



unverbindliche Plan- und Gestaltungsvorschläge / alle Maße sind ca. Maße / kleine Änderungen vorbehalten

